





GENUINE Interior Lighting Kit

INSTALLATION INSTRUCTIONS

Thank you for purchasing a genuine Mazda accessory.
Before removal and installation, be sure to thoroughly read these instructions.
Please read the contents of this booklet in order to properly install and use the Interior lighting kit.
Your safety depends on it.
Keep these instructions with your vehicle records for future reference.

WARNING

- There are several  **WARNING** and  **CAUTION** sections in this booklet concerning safety when installing or removing the Interior lighting kit. Always read and follow them in order to prevent injuries, accidents, and possible damage to the vehicle.
 -  **WARNING:** Indicates a situation in which serious injury or death could result if the warning is ignored.
 -  **CAUTION:** Indicates a situation in which bodily injury or damage to the vehicle could result if the caution is ignored.
- For areas indicating the tightening torque in this instruction manual, tighten to the specified torque using a torque wrench.
- Do not modify the Interior lighting kit.
- Do not install the Interior lighting kit remove in any way other than described in the following instructions.
- If in any doubt, please ask your Mazda dealer to install the accessory in order to prevent errors in installation.
- If you have any questions about the use of the accessory, ask your Mazda dealer for proper advice before using it.
- Mazda and its suppliers are not responsible for injuries, accidents, and damage to persons and property that arise from the failure of the dealer or installer to follow these instructions.
- To ensure safety and reliability of the work, installation, removal and disposal work must be carried out by an Authorized Mazda Dealership.
- Be careful not to lose removed parts, and be sure that they are kept free from scratches, grease or other dirt.

PART NAME: Interior Lighting kit
VEHICLE: MAZDA3
PART NUMBER: BHP1 V7 050

NOTE

To the dealer

- Please turn over these instructions to the customer after installation.













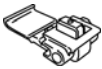

To the customer

- Keep these instructions after installation. The instructions may be necessary for installing other optional parts or removal of this accessory.
- Should the vehicle or this accessory be resold, always leave these instructions with vehicle for the next owner.

1. PARTS

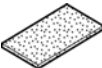
Note

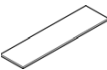
- Before installation, verify that the kit includes all the following parts and that they are free of dirt, scratches, or damage.

Part	Part name	Qty.	Part	Part name	Qty.	Part	Part name	Qty.
	Control unit	1		Main harness	1		LED lamp (G44N V7 052)	2
	Switch harness Switch label (E223 V7 055)	1		Electro tap	3		Mount base A	1
	Mount base B	3		Tie wrap (small)	1		★ Tie wrap (large)	22
	A-pillar clip (D651 68 162)	1		★ Cushioning tape	5		Double-sided adhesive tape A	3
	Double-sided adhesive tape B	1		Installation instructions	1		Installation inspection sheet User's instructions Template	1ea.

★ The quantity necessary depends on the method of installation.

Installation view

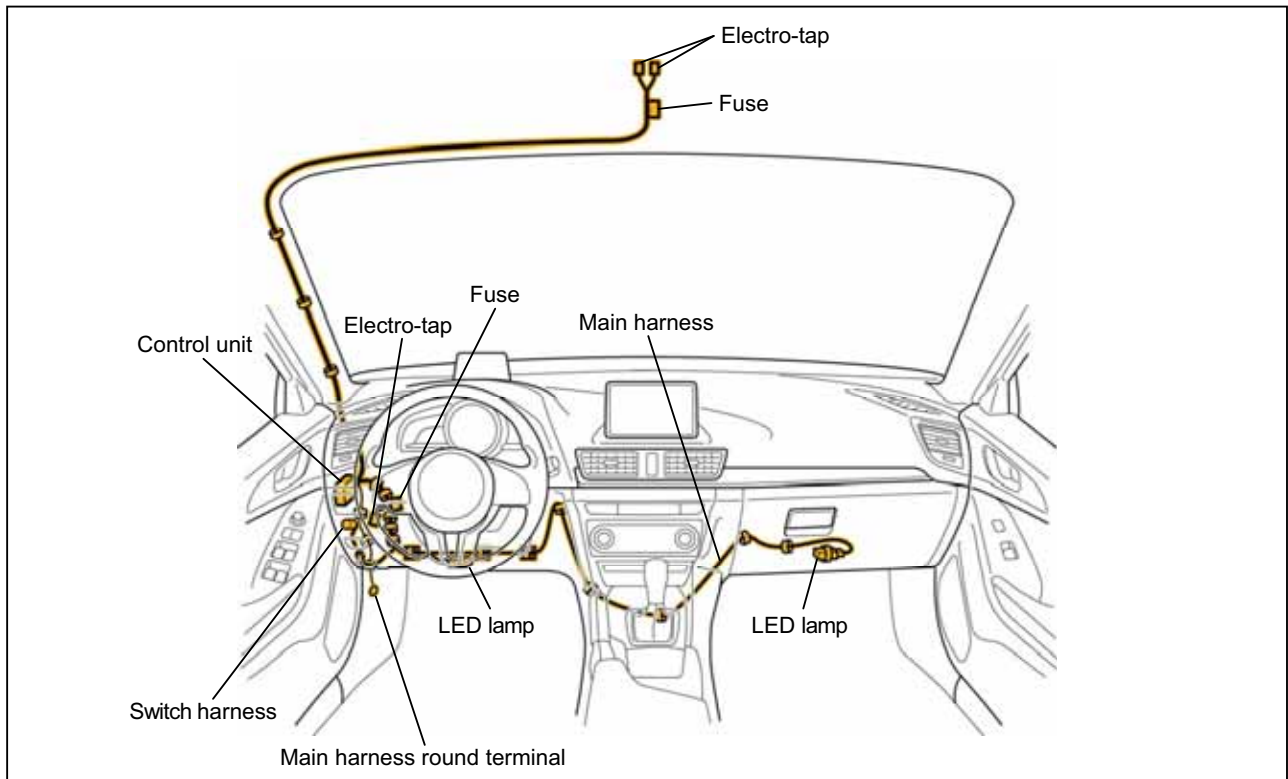

2. CONNECTION DIAGRAM

Figure shows connector viewed from harness side.

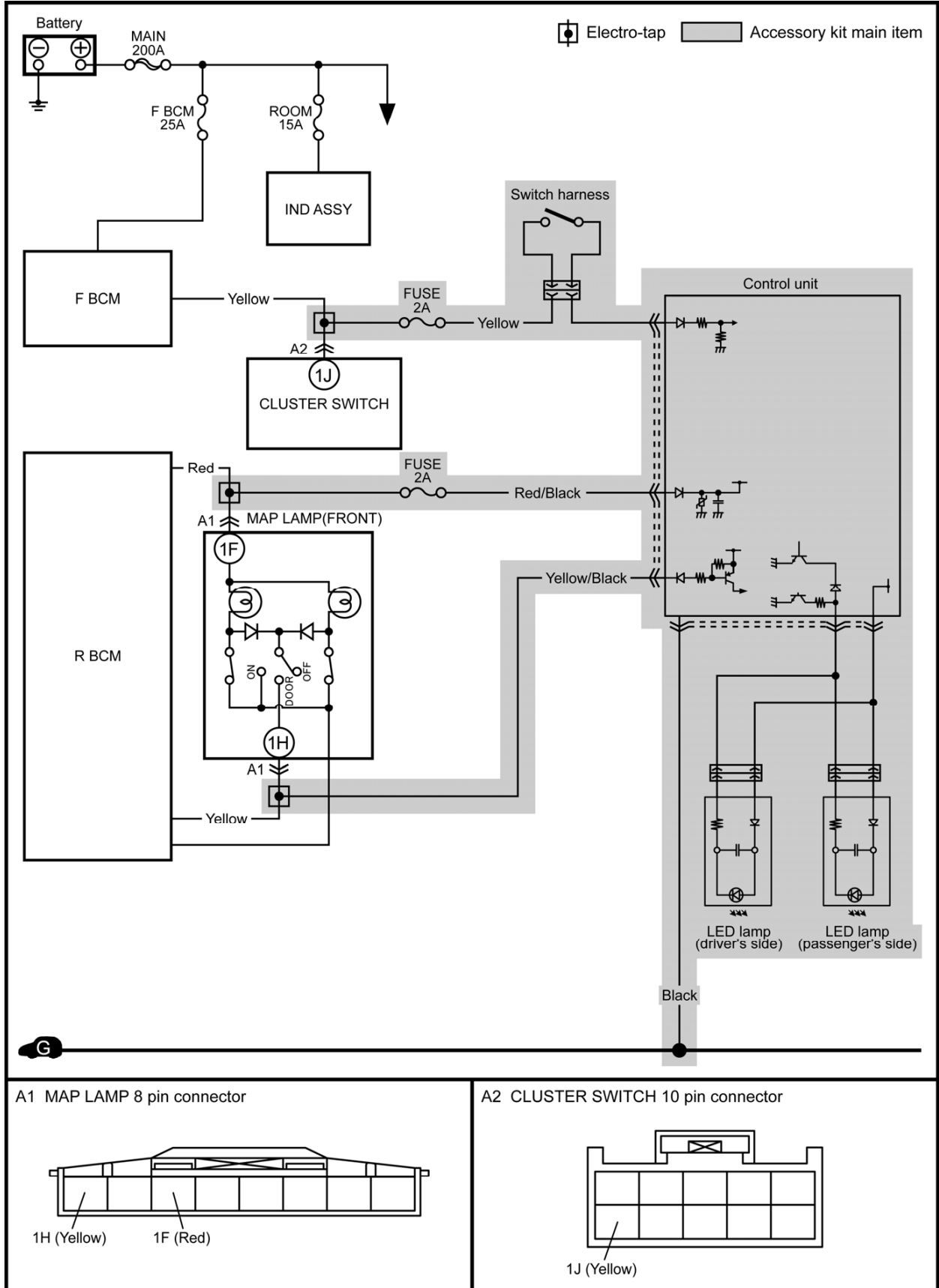







3. REQUIRED TOOLS

- ☆Screwdriver (Flathead) ☆Screwdriver (Phillips) ☆Socket wrench ☆Torque wrench ☆Nipper
- ☆Pliers ☆Drill (2mm, 5mm, 9mm) ☆Hole saw (20 mm) ☆Pin ☆Round file ☆Scissors
- ☆Flathead screwdriver wrapped with protective tape ☆Fastener remover wrapped with protective tape
- ☆Electrical vinyl tap ☆Masking tape ☆Soft clean cloth ☆Mat ☆IPA (Isopropyl alcohol)

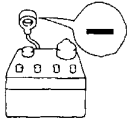

4. BEFORE INSTALLATION

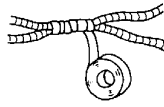
- To perform the installation work safely and maintain functionality and quality, thoroughly read these instructions before performing the procedures and always heed the warnings and precautions.
- In the work procedures, there are descriptions which are only indicated in the illustrations. Make sure to follow these procedures as well.

⚠ WARNING

			
When the negative battery cable is connected during operation, it may cause electric shock or other personal injuries. Disconnect the negative battery cable before removal/installation.	Before performing any work, park the vehicle on level ground, apply the parking brake securely, and then block the wheels.	Be careful when handling drills and other sharp objects. If not handled properly, it could result in serious injury.	
			
When connecting/disconnecting connectors, grasp the connectors, not the wires. Otherwise a short, and an accident from poor contact or fire may occur.	Make sure the connector is securely pressed in until a click sound is heard. Otherwise, a fire or other accident may occur due to an open circuit or poor contact.	Secure the harness with the band (part included) so it doesn't dangle. If not, it may cause a short, accident, or fire.	Do not pull the harness with excessive force. Doing so can cause a breakage or a short-related accident, as well as an electrical short or fire.

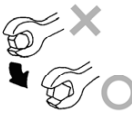
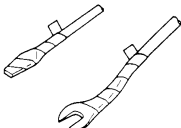
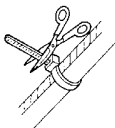
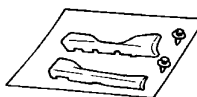
⚠ CAUTION

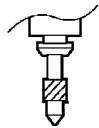
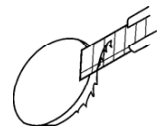
			
Using improper tools may cause damage and/or broken parts. Use the correct tool for the job.	Wrap protective tape around screwdrivers and fastener remover tools to prevent scratching the vehicle.	Excessive length of tie wrap may interfere with other parts and cause damage.	Put the removed parts and the parts in the kit on the protective sheet to prevent scratches.
			
If tape or a mount base is to be adhered, always remove dirt or oil from the adhesion surface using IPA (isopropyl alcohol). Otherwise the adhesive strength will be weakened.	If tape or a mount base is re-adhered, the adhesive strength will be weakened. Before adhering, accurately determine the adhesion position.	When drilling, hold the drill or hole saw perpendicular to the drilling surface to prevent the drill position from deviating.	Make sure to remove burrs from the surface so that the bumper surface is smooth.

5. VEHICLE PART REMOVAL

⚠ CAUTION

- Be careful not to damage or lose any parts removed from the vehicle since they will be reused.

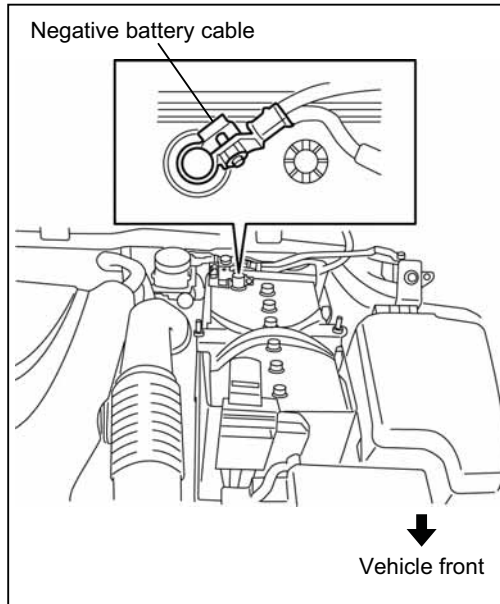

Negative battery cable disconnection

1. Set the selector lever to P range.
(AT vehicles only)

⚠ WARNING

- When removing/installing the parts, park the vehicle on level ground and apply the side brake securely. Be sure to turn the ignition switch off, otherwise the vehicle can move, causing personal injury or vehicle damage.

2. Disconnect the negative battery cable and wrap tape around it to insulate.

⚠ WARNING

- When the negative battery cable is connected during operation, it may cause electric shock or other personal injuries. Disconnect the negative battery cable before removal/installation.

Tightening torque : 4.0-6.0 N·m

Glove compartment removal

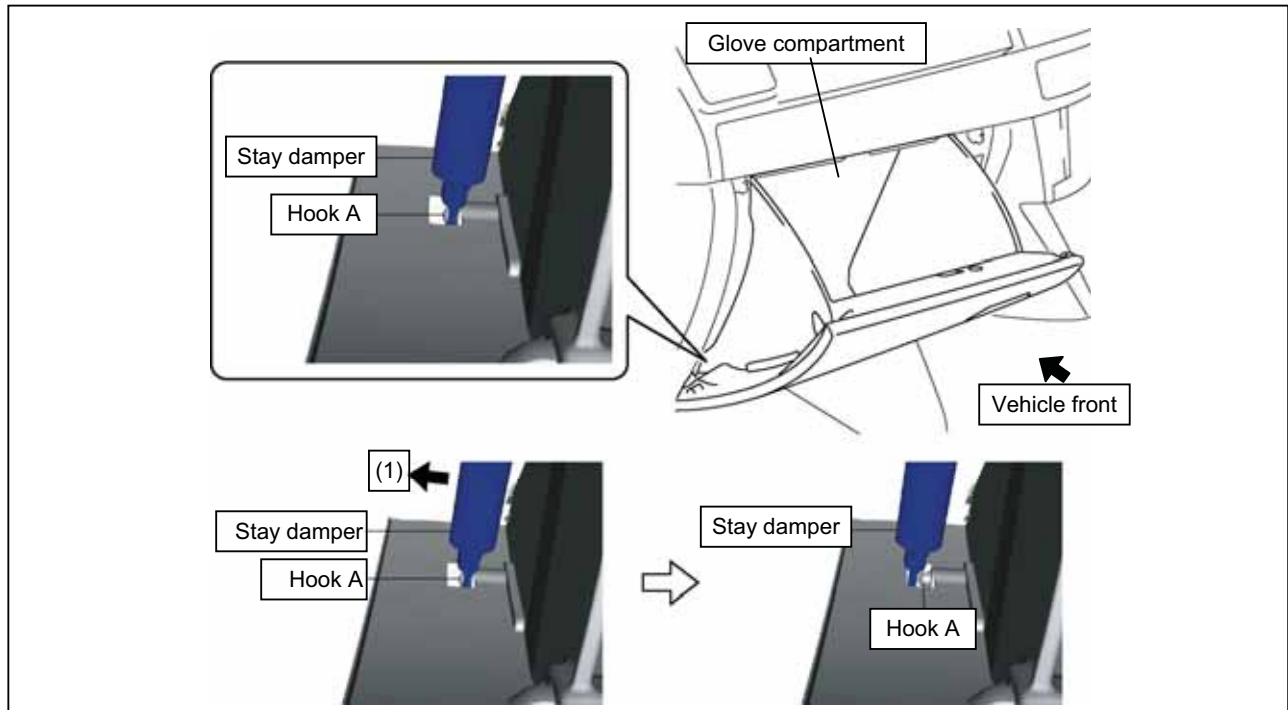

1. Open the glove lid.
2. Pull the stay damper in the direction of the arrow (1) shown in the figure and remove the hook A.

⚠ CAUTION

- If the glove compartment is closed without being joined to the stay damper, the stay damper may be damaged. Verify that the stay damper is joined to the glove compartment before closing the glove compartment.

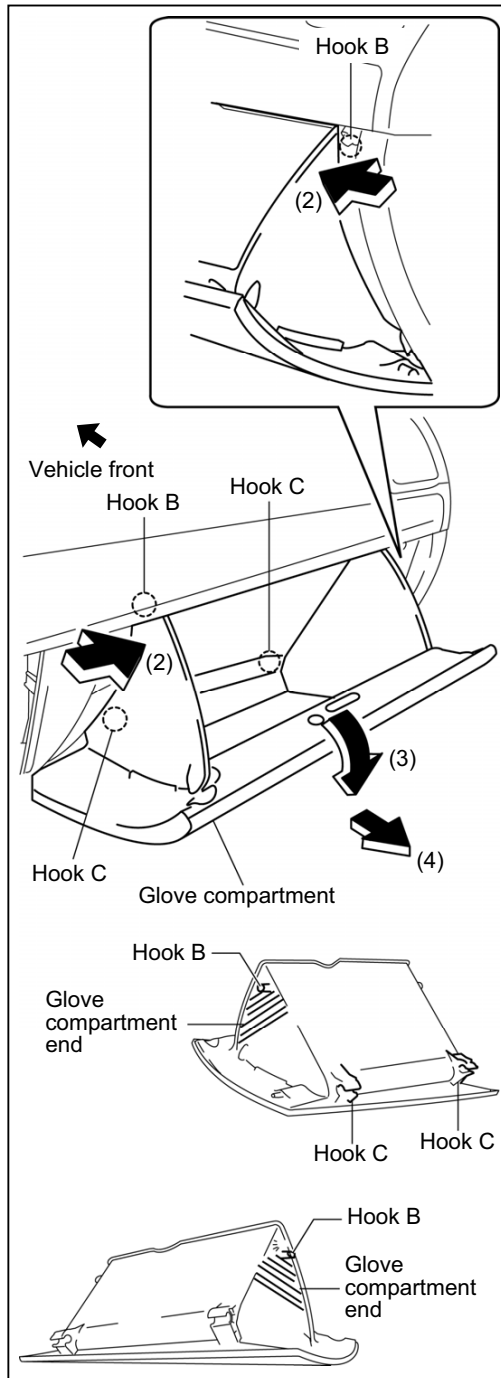

3. Push the glove compartment end in the direction of the arrow (2) and remove hooks B.

CAUTION

- When disengaging hooks B, the hooks could interfere with the lower panel and cause scratches or damage. When removing hooks B, press in the ends of the glove compartment to a location which does not interfere with the lower panel.

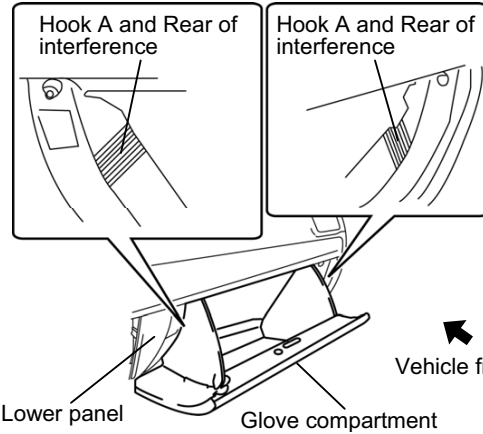

4. Pull down the glove compartment in the direction of the arrow (3).

5. Pull the glove compartment in the direction of the arrow (4) and remove it while detaching hooks C.

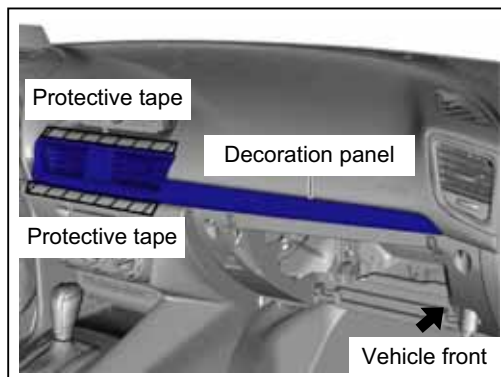

Decoration panel removal

CAUTION

- To prevent scratches or damage, apply protective tape to the position shown in the figure.

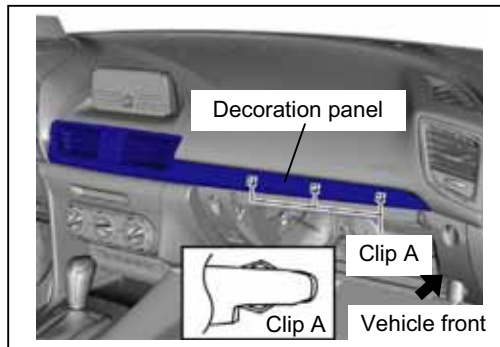

1. Insert a hand into the glove compartment opening and press out clips A shown in the figure towards the rear of the vehicle.

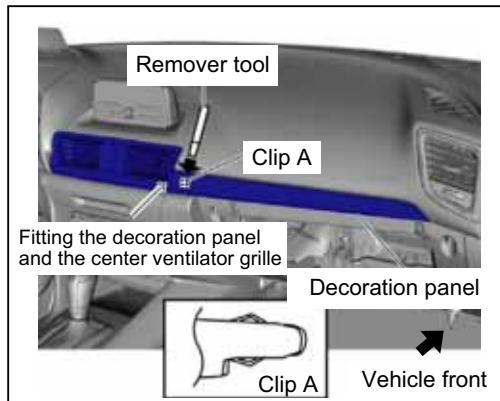

2. Insert a hand into the glove compartment opening, and while pressing clip A with a finger, insert the remover tool into the position shown in the figure, move the decoration panel, and disengage decoration panel clip A from the lower panel.

⚠ CAUTION

- If the decoration panel is pulled with excessive force when disengaging clip A, the center ventilator grille and decoration panel connection could be damaged. When disengaging clip A, be careful not to damage the decoration panel.

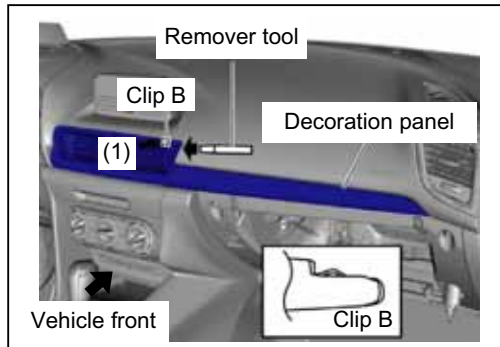

3. Insert the remover tool into the position shown in the figure and move the decoration panel in the direction of arrow (1) shown in the figure, and disengage clip B from the dashboard.

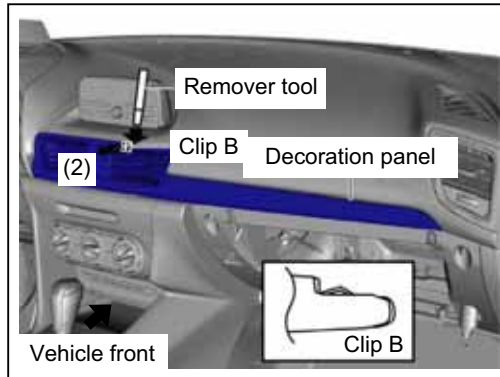

4. Insert the remover tool into the position shown in the figure, move the decoration panel in the direction of arrow (2) shown in the figure, and remove clip B from the dashboard.

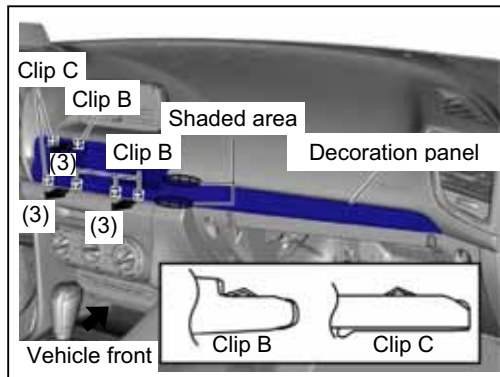

5. Hold the shaded areas shown in the figure, pull the decoration panel straight out in the direction (towards rear of vehicle) of arrows (3) shown in the figure, and disconnect clips B, clips C from the instrument panel.

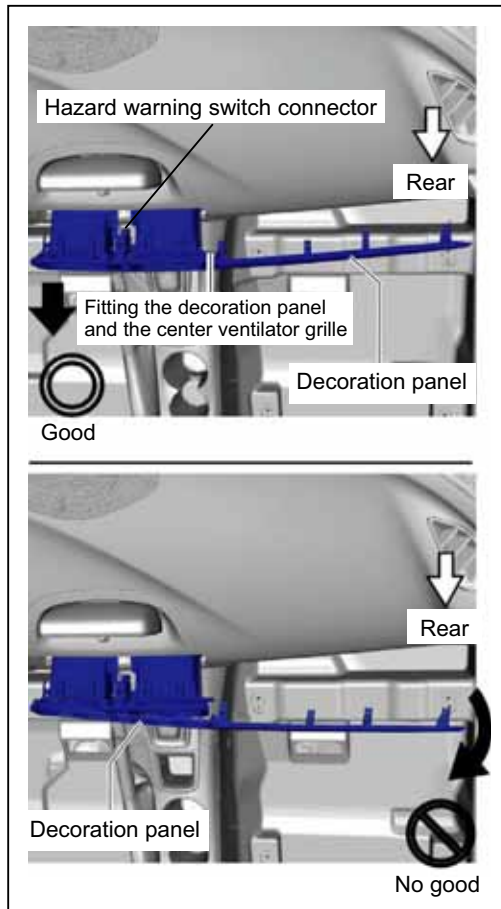

6. Disconnect the hazard warning switch connector.

⚠ CAUTION

- If the decoration panel is pulled out while tilted, the center ventilator grille and decoration panel connection could be damaged. Pull the decoration panel straight out toward the rear of the vehicle when removing.

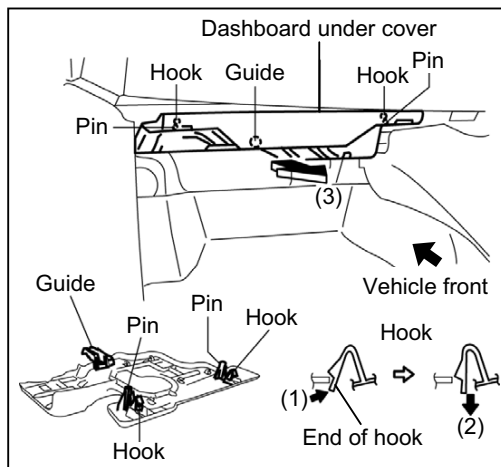

Dashboard under cover removal

1. Detach hooks in the direction of the arrows in the order of (1), (2) shown in the figure.

⚠ CAUTION

- If the decoration panel is pulled out while tilted, the center ventilator grille and decoration panel connection could be damaged. Pull the decoration panel straight out toward the rear of the vehicle when removing.

2. Remove the dashboard under cover in the direction of the arrow (3) shown in the figure while detaching the guide.

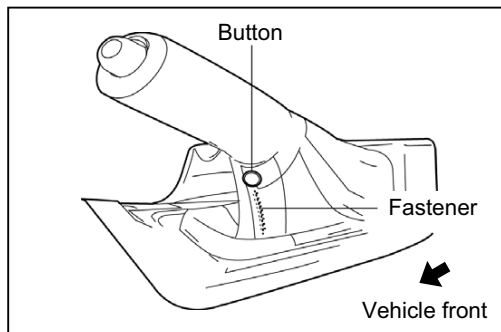

Upper panel removal

1. Open the console lid.
2. Remove the button, then open the fastener.

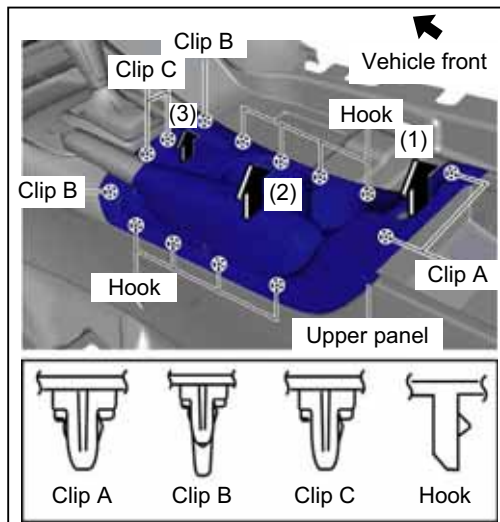

- Pull the upper panel in the order of arrows (1), (2), and (3) as shown in the figure and remove it while detaching clips A, hooks, clips B and clips C.
- Disconnect the commander switch connector (with commander switch).

Note

- When clips B are removed at the front of the upper panel, clips for the rear of the shift panel may be disengaged.

CAUTION

- If the upper panel is installed with the upper panel hooks not inserted into the grooves of the console, the hooks could come out or be bent inward and damaged. Verify that the hooks are inserted into the grooves and then install.

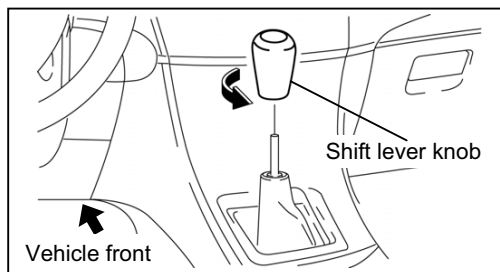

Shift lever knob removal

[MTX]

- Remove the shift lever knob.

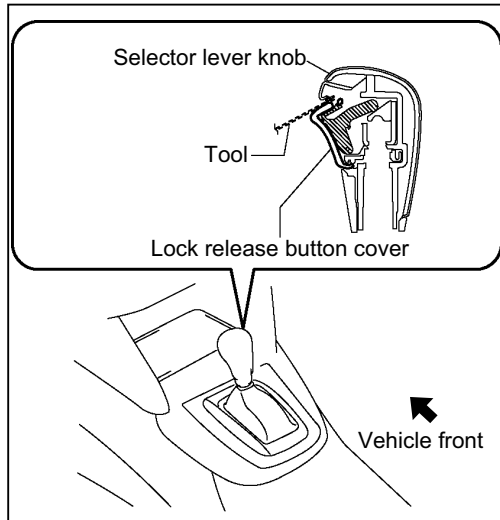

Selector lever knob removal

[ATX]

Note

- If the servicing is difficult, release the shift lock manually and shift the selector lever to the N position.

- Insert the tool (width: 6 mm {0.2 in} or less, thickness: 1 mm {0.04 in} or less) as shown in the figure.

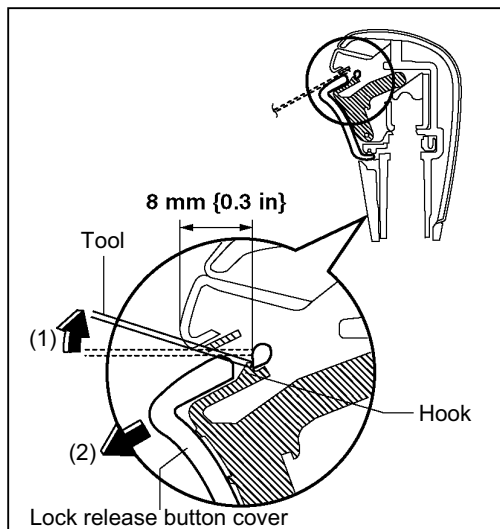

- Move the tool in the direction of arrow (1) in the figure and detach the hook. Move the lock release button cover in the direction of arrow (2) in the figure and remove it.

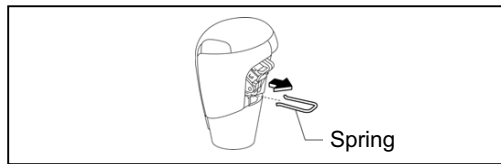

3. Remove the spring.

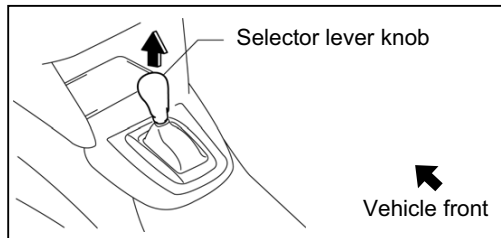

4. Remove the selector lever knob.

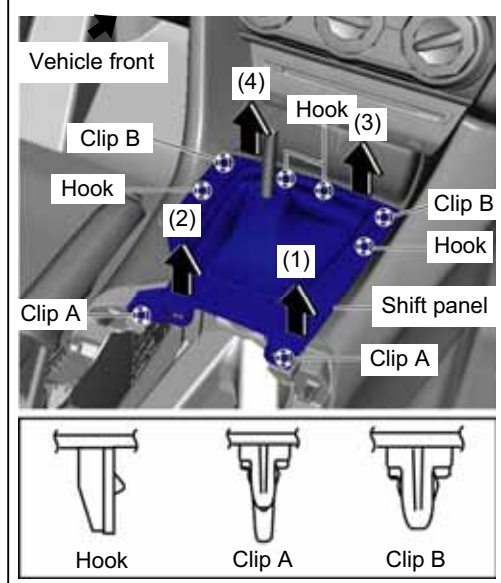

Shift panel removal 【MTX】

1. Remove the shift panel in the direction of the arrows in the order of (1), (2), (3), (4) while detaching hooks, clips A and clips B.

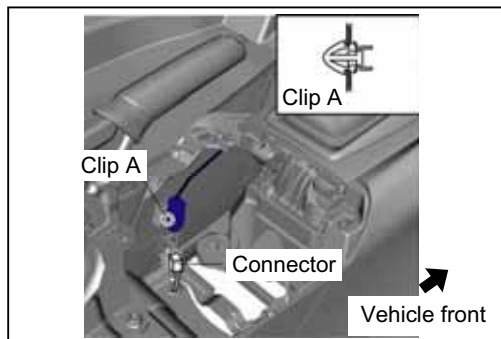

【ATX】

1. Remove clip A.
2. Disconnect the connector.

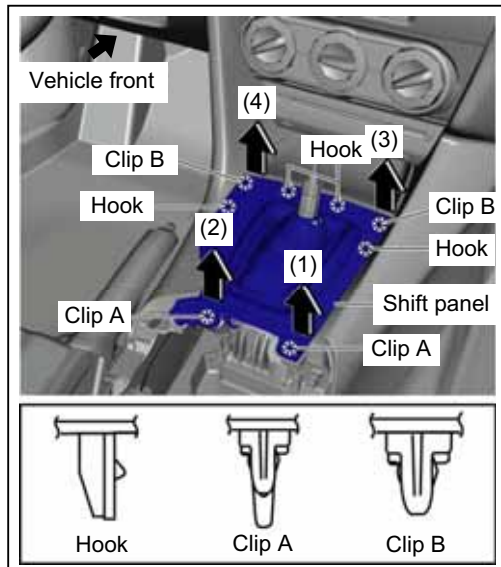

3. Remove the shift panel in the direction of the arrows in the order of (1), (2), (3), (4) while detaching hooks, clips A and clips B.

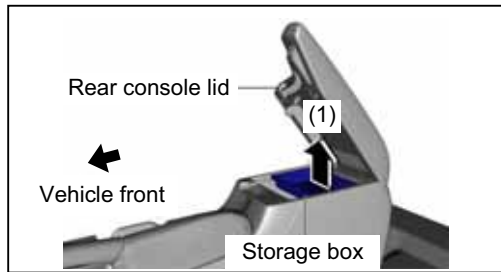

Rear console removal

1. Open the rear console lid.
2. Remove the storage box in the direction of the arrow (1) shown in the figure.

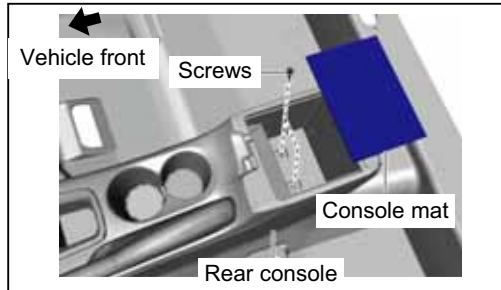

3. Remove the console mat.
4. Remove screws.

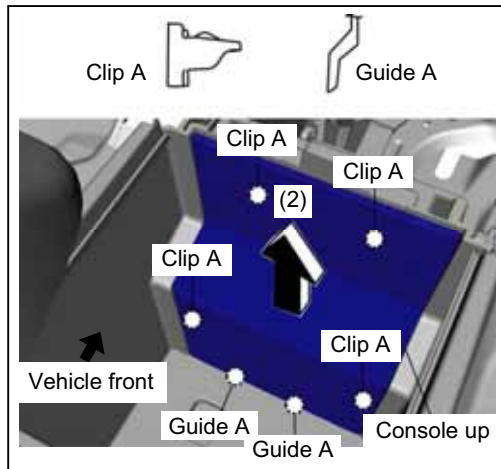

5. Pull the console up in the direction of the arrow (2) and remove it while detaching clips A, guides A.
6. Disconnect the auxiliary jack/usb port/sd card slot hub connector. (with auxiliary jack/usb port/sd card slot hub)
7. Disconnect the auxiliary jack/usb port connector. (with auxiliary jack/usb port)
8. Disconnect the accessory socket connector. (with accessory socket)

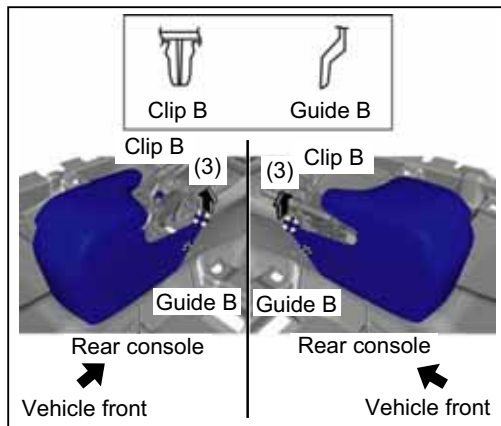

9. Pull the rear console in the direction of the arrow (3) and remove it from the front console while detaching clips B, guides B.

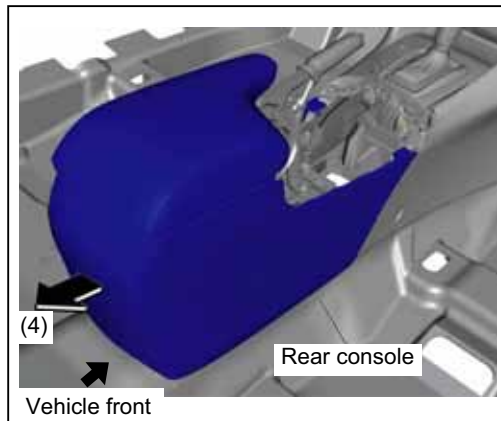

10. Remove the rear console in the direction of the arrow (4) shown in the figure.

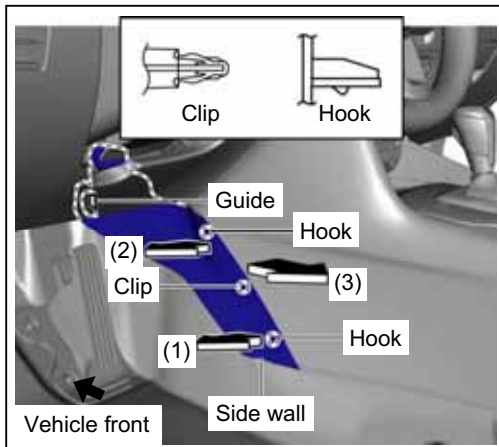

Side wall (driver's side) removal

1. Pull the side wall in the direction of the arrow in the order of (1), (2) and remove it while detaching hooks and clip.

CAUTION

- If hooks and clip are removed forcefully, guide may be damaged. Carefully remove hooks and clip so as not to damage guide.

2. Pull the side wall in the direction of the arrow (3) and remove it while detaching guide.

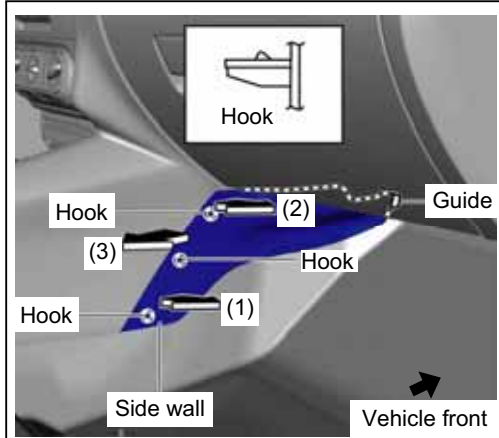

Side wall (passenger's side) removal

1. Pull the side wall in the direction of the arrow in the order of (1), (2) and remove it while detaching hooks.

CAUTION

- If hooks are removed forcefully, guide may be damaged. Carefully remove hooks so as not to damage guide.

2. Pull the side wall in the direction of the arrow (3) and remove it while detaching guide.

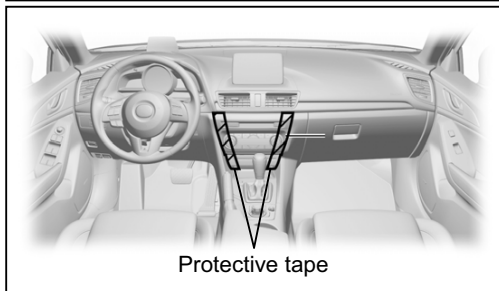

Front console removal

CAUTION

- Affix protective tape to the position shown in the figure.

1. Remove fasteners.

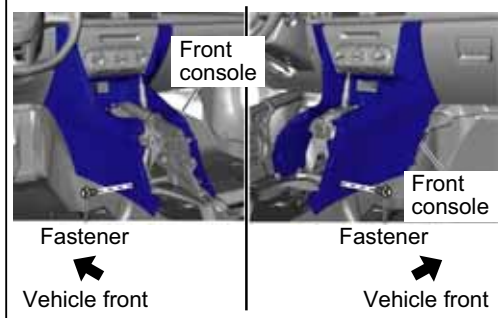

2. Pull the front console in the direction of the arrow in the order of (1), (2), (3), (4) and remove it while detaching clips A, clips B.

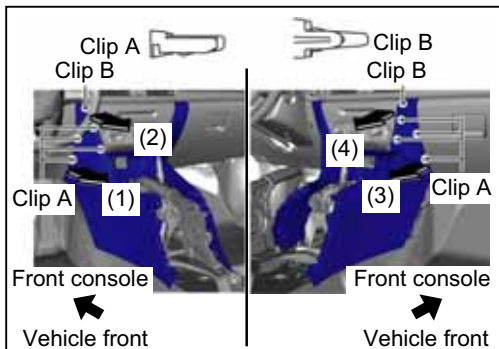

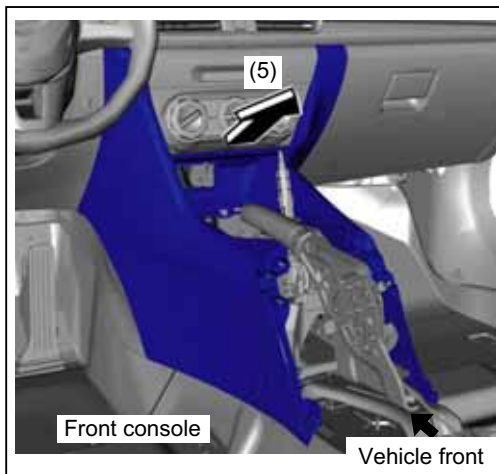

3. Operate the parking lever, move the front console in the direction of arrow (5), and remove the front console while setting the parking brake lever aside.
4. Disconnect the connector.
5. Apply the parking brake.

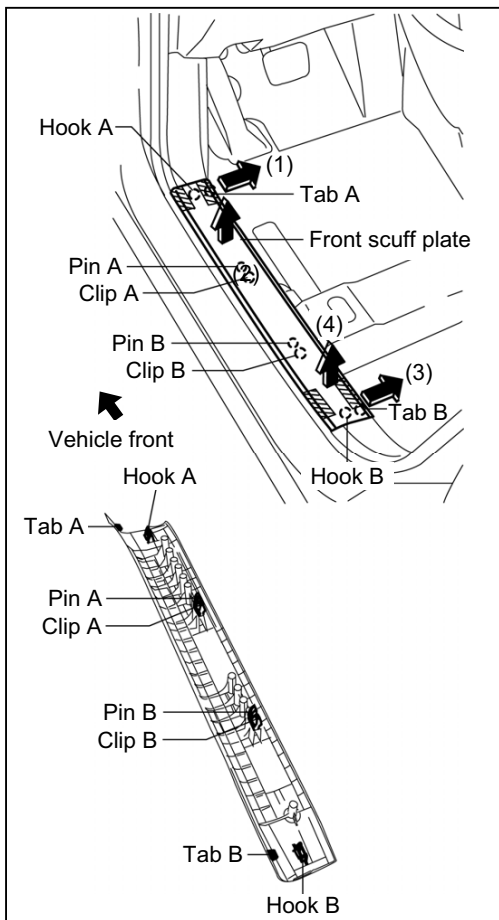

Front scuff plate (driver's/passenger's side) removal

1. Grasp the shaded area shown in the figure, detach tab A while pulling the front scuff plate in the direction of the arrow (1) shown in the figure, then detach the hook A, clip A, and pin A while pulling in the direction of the arrow (2).
2. Grasp the shaded area shown in the figure, detach tab B while pulling the front scuff plate in the direction of the arrow (3) shown in the figure, then detach the hook B, clip B and pin B while pulling in the direction of the arrow (4).

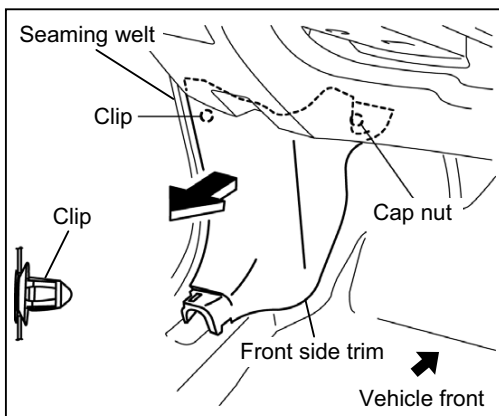

Front side trim (driver's/passenger's side) removal

1. Partially peel back the seaming welt.
2. Remove the cap nut.
3. Pull the front side trim in the direction of the arrow shown in the figure and remove it while detaching the clip.

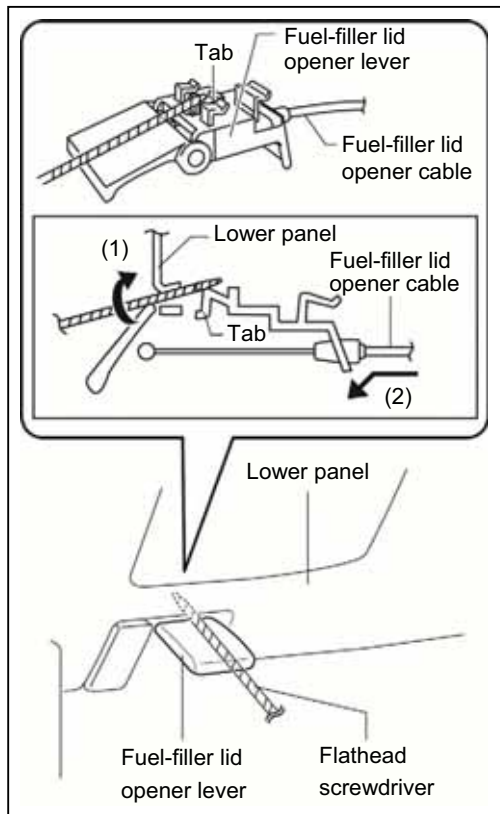

Fuel-filler lid opener lever removal

1. While pulling the fuel-filler lid opener lever, insert a tape-wrapped flathead screwdriver into the position shown in the figure.
2. Move the tape-wrapped flathead screwdriver in the direction of arrow (1) shown in the figure to press the tab, and pull the fuel-filler lid opener cable in the direction of arrow (2) to detach the fuel-filler lid opener lever from the lower panel.

⚠ CAUTION

- Remove the fuel-filler lid opener lever while being careful not to damage the fuel-filler lid opener cable with the flathead screwdriver.

3. Pull the fuel-filler lid opener lever to remove it from the lower panel.

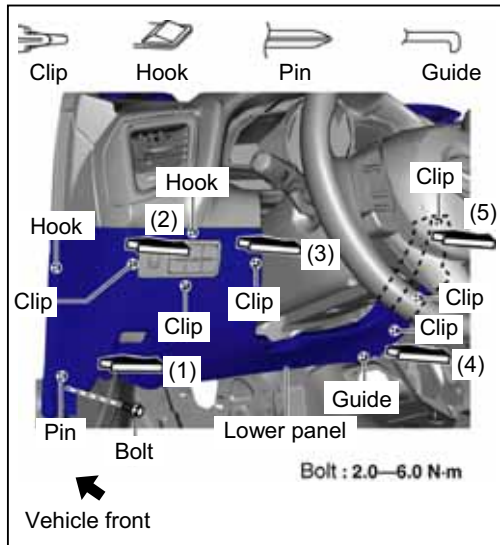

Lower panel (driver's side) removal

1. Remove bolt.
2. Pull the driver-side lower panel in the direction of the arrow in the order of (1), (2), (3), (4), (5) while detaching clip, hooks, pin and guide.
3. Disconnect the trunk lid opener switch connector.

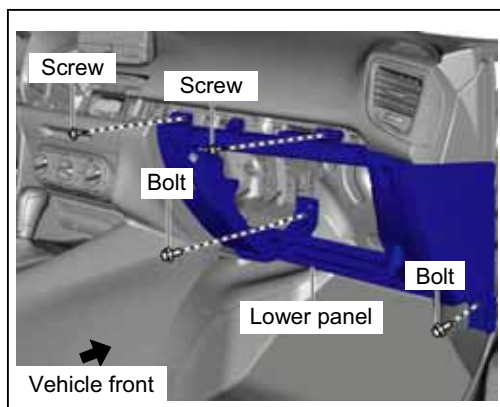

Lower panel (passenger's side) removal

1. Remove bolts.
2. Remove screws.

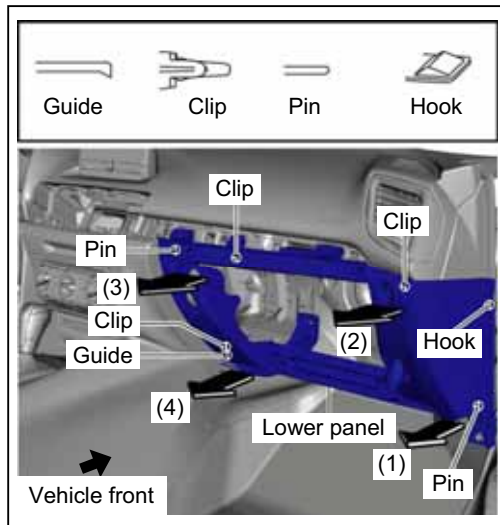

3. Pull the passenger-side lower panel in the direction of the arrow in the order of (1), (2), (3), (4) and remove it while detaching clips, hook, pin and guide.

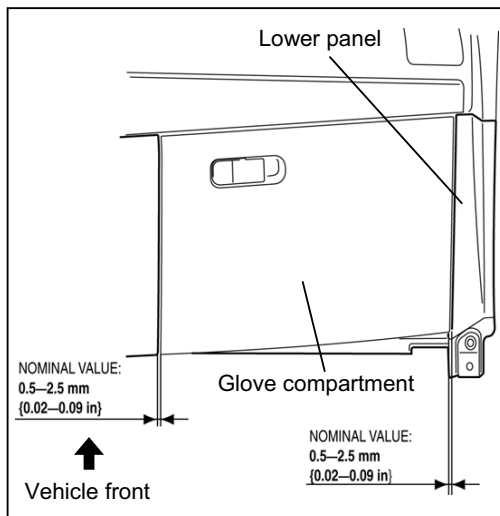

■ Lower panel (passenger's side) installation note

- After installing the passenger-side lower panel and glove compartment, measure the clearance, and verify that the measurement value is within the specification shown in the figure.

⚠ CAUTION

- If the measurement value is not within the specification after measuring the clearance between the passenger-side lower panel and glove compartment, adjust the passenger-side lower panel to the proper position.

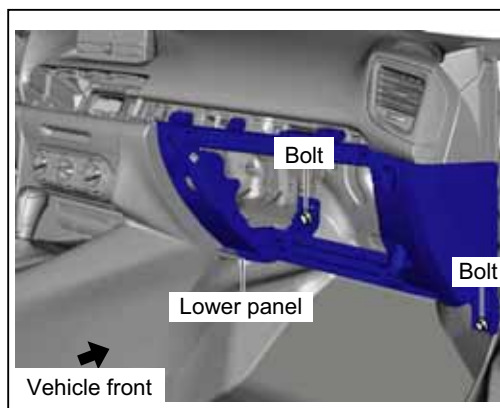

■ Lower panel (passenger's side) adjustment

1. Loosen bolts.

⚠ CAUTION

- If the passenger-side lower panel moves in the lateral direction when bolts are loosened, go to the Step 3 and 4.
- If the passenger-side lower panel does not move in the lateral direction when bolts are loosened, go to the Step 5.

2. Remove bolts.

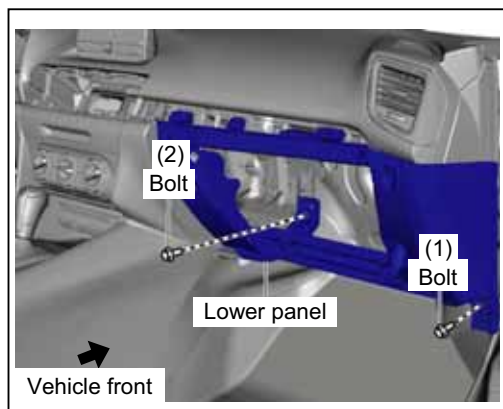

3. Install bolts in the order of (1), (2) shown in the figure.

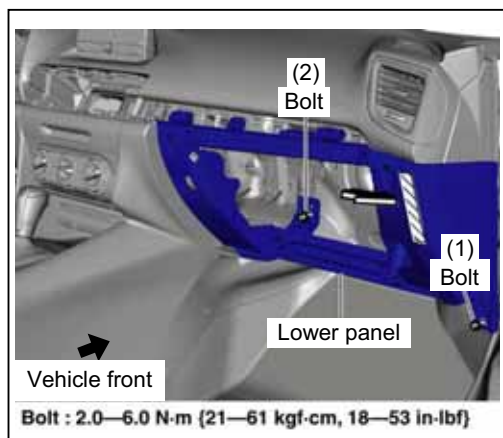

4. Install bolts in the order of (1) and (2) while pressing the shaded area shown in the figure for the passenger-side lower panel.
5. Install the glove compartment, measure the clearance between the glove compartment and passenger side lower panel again, and verify that it is within the specification.

⚠ CAUTION

- If it is not within the specification after measuring the clearance, repeat the adjustment procedure from Step 1.

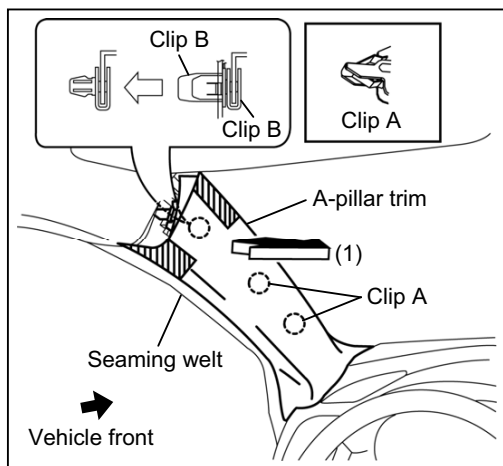

A-pillar trim (driver's side) removal

1. Partially peel back the seaming welt.
2. Grasp the shaded areas shown in the figure, and pull the A-pillar trim in the direction of the arrow (1) while detaching clips A, clip B.

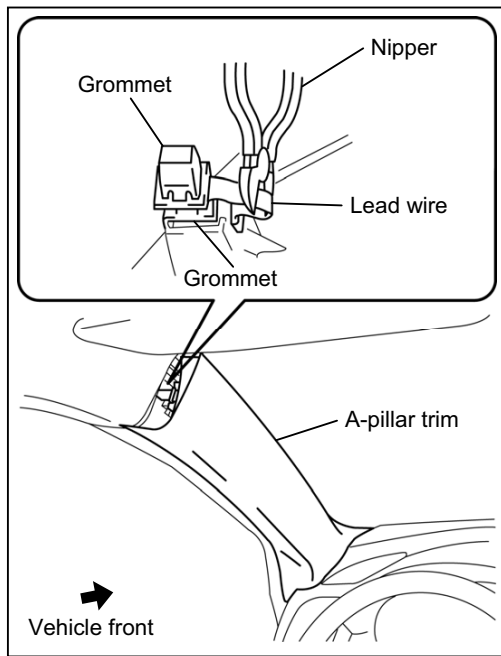

3. Cut the lead wire connecting clips B and grommet using a nipper.

CAUTION

- Do not re-use clips B and the grommet.
- When installing the A-pillar trim, install new trim clips (D651 68 162)

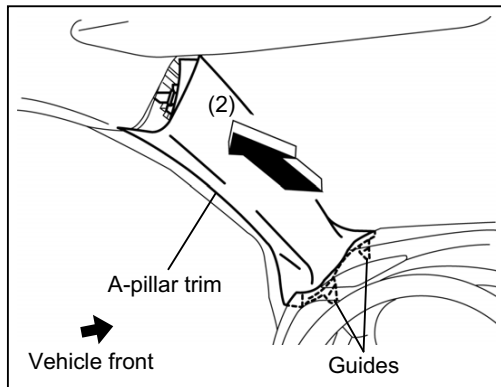

4. Pull the A-pillar trim in the direction of the arrow in the order of (2) and remove the A-pillar trim while detaching guides.

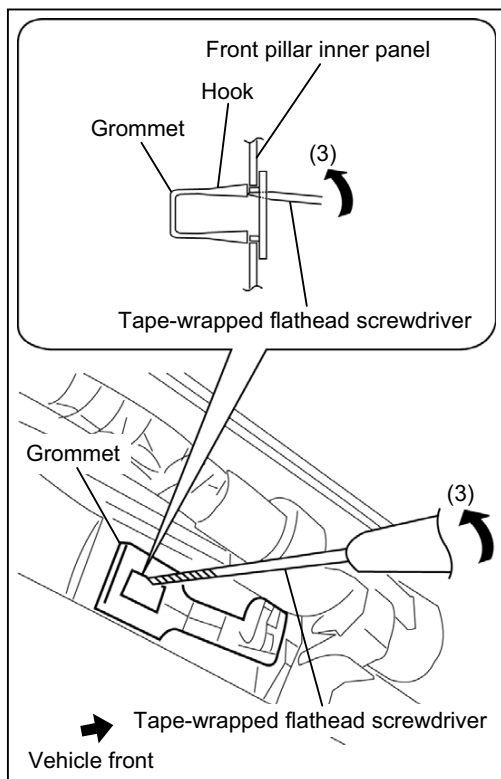

5. Move the hook in the direction of arrow (3) shown in the figure using a tape-wrapped flathead screwdriver and detach it from the front pillar inner panel.

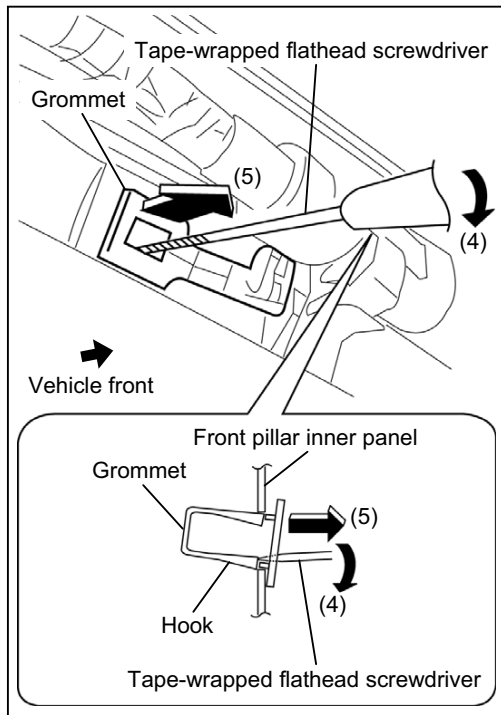

6. Move the hook in the direction of arrow (4) shown in the figure using a tape-wrapped flathead screwdriver and detach it from the front pillar inner panel.
7. Remove the grommet in the direction of the arrow (5) shown in the figure.
8. When installing the A-pillar, install new clips B and grommet to the A-pillar trim in advance.

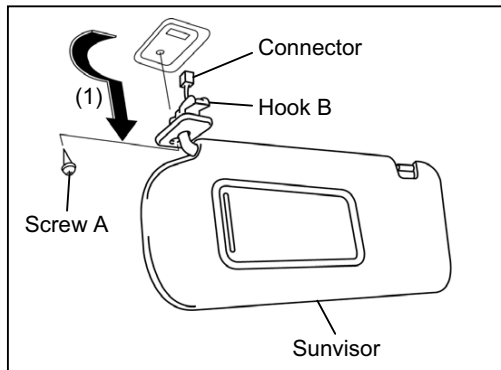

Sunvisor (driver's side) removal

1. Remove screw A.
2. Remove the sunvisor in the direction of the arrow (1) shown in the figure while detaching hook B.
3. Disconnect the vanity mirror illumination connector (with vanity mirror illumination).

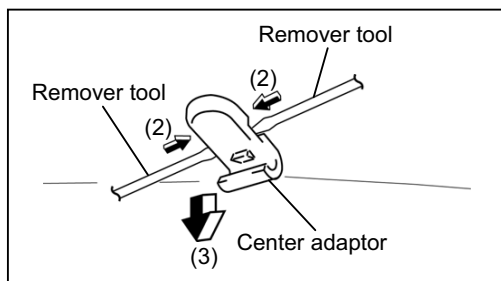

4. Press the center adaptor tabs in the direction of the arrow (2) shown in the figure using two remover tool.

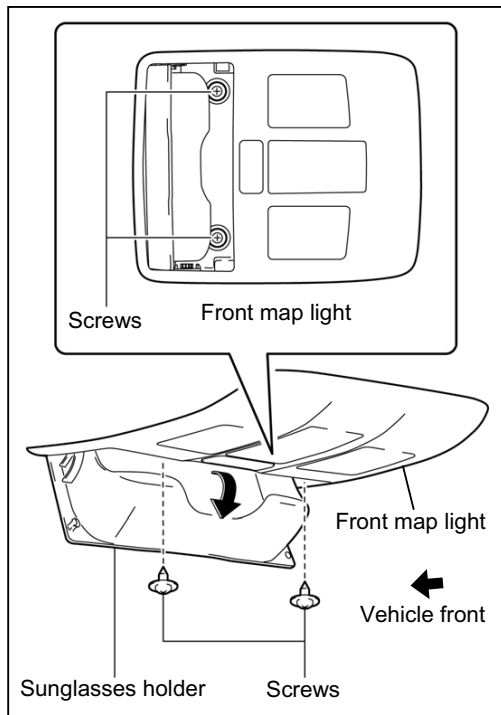

Front map light removal

1. Remove the screws.

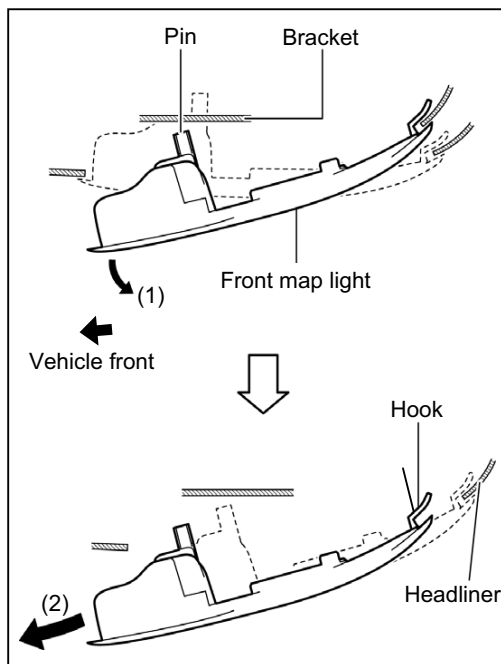

2. Move the front map light in the direction of arrow (1) shown in the figure and pull out the pin from the bracket.

⚠ CAUTION

- Be careful not to pull the connector out strongly when removing the front map light. Otherwise, the contact surface of the wiring harness secured to the headliner will come off and the wiring harness could be pulled out. If the front map light is installed with the wiring harness pulled out, the wiring harness could get caught between the headliner and front map light bracket resulting in an open or short circuit in the wiring harness.

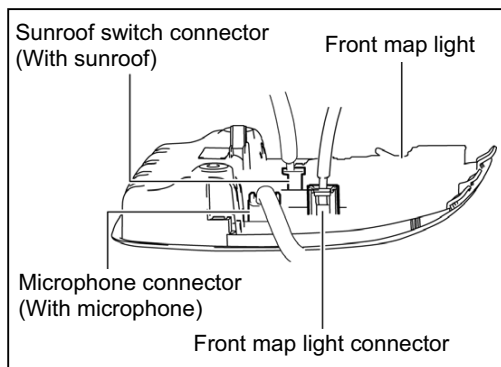

3. Move the front map light in the direction of arrow (2) shown in the figure and pull out the front map light from the headliner.
4. Disconnect the connector and remove the front map light from the headliner.

⚠ CAUTION

- When removing the front map light from the headliner, the front map light may fall off and be damaged. Remove the front map light from the headliner while holding the front map light on the lens side by hand.

6. PREPARATION FOR INSTALLATION

■ Cutting double-sided adhesive tape B

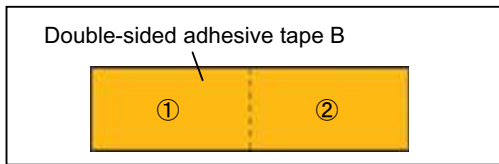

1. Cut double-sided adhesive tape B in half and write the number ① on one half and ② on the other.

■ Cutting the cushioning tape

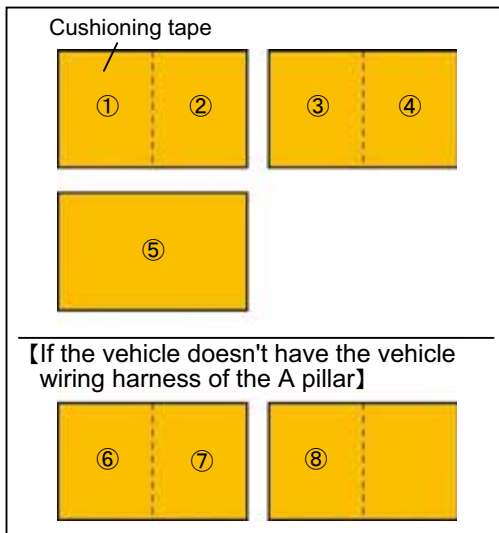

1. Cut the cushioning tape in half and number them as shown in the left figure.

⚠ CAUTION

- Some vehicle don't have the vehicle wiring harness of the A pillar. In that case, use two cushioning tapes as shown in the left-below figure.

■ Dashboard under cover processing

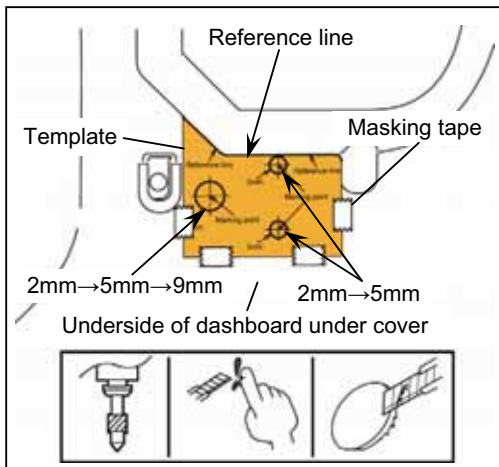

1. Cut out the templates with scissors along the cut lines.
2. Align the template reference line as shown in the figure and affix it with masking tape.
3. Make drilling marks using a pin in the center of the drilling positions (5 mm, 9 mm) of the template.
4. Remove the template.
5. Drill holes from the underside of the dashboard under cover in the marked positions, in the order of 2 mm to 5 mm and 2 mm to 5 mm to 9 mm.

■ Lower panel (driver's side) processing

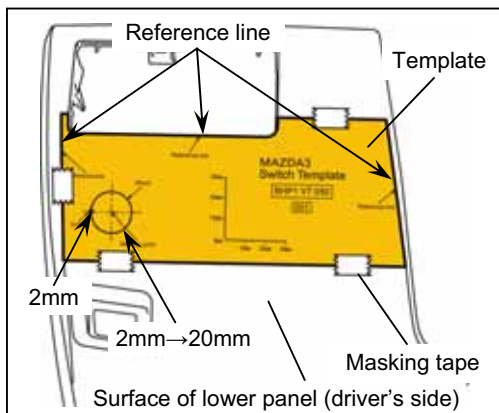

1. Cut out the template with scissors along the cut lines.
2. Align the templates reference line as shown in the figure and affix it with masking tape.
3. Make drilling marks using a pin in the center of the drilling positions (2 mm, 20 mm) of the template
4. Remove the template.

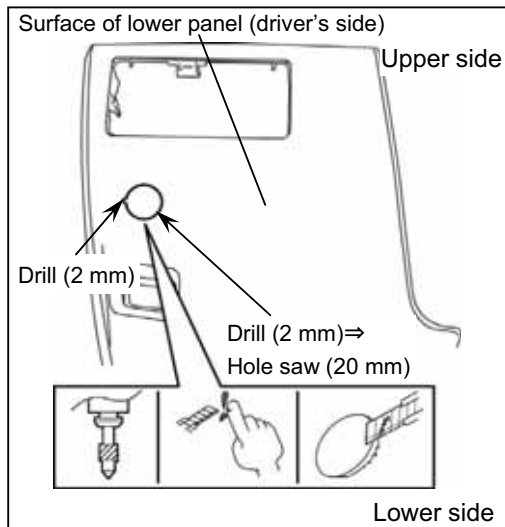

5. Drill 2 mm holes in two locations at the marked positions from the underside of the lower panel (driver's side).
6. Using a hole saw (20 mm), drill the switch harness installation hole.

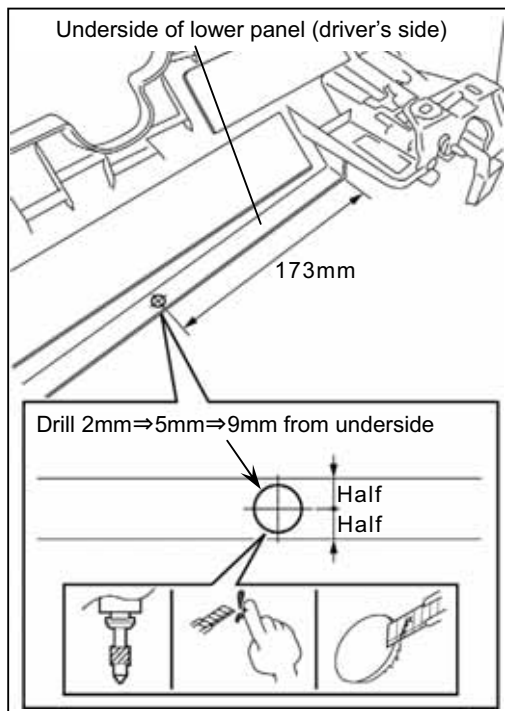

7. Make a drilling mark using a pin in the position shown in the figure on the left from the underside of the lower panel (driver's side).

⚠ CAUTION

- If the drilling position is not on center, the lower panel (driver's side) could be damaged when drilling. Mark the drilling position accurately.

8. Drill holes from the underside of the lower panel (driver's side) in the marked positions, in the order of 2 mm to 5 mm to 9 mm.

■ Switch harness installation

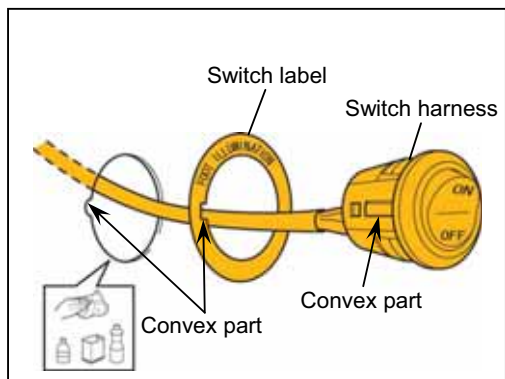

1. Remove the paper backing from the switch label and adhere the label to the front side of the lower panel (driver's side).
2. Install the switch harness by passing it through from the surface of the lower panel (driver's side).

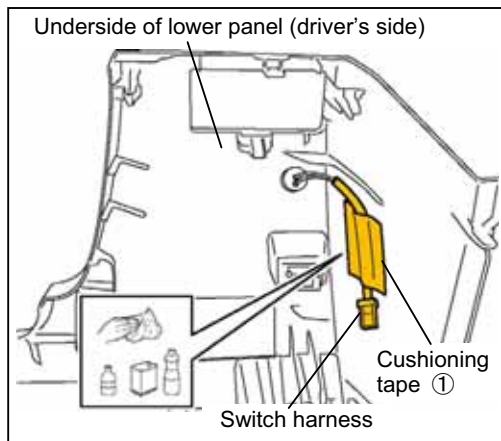

3. Secure the switch harness to the underside of the lower panel (driver's side) as shown in the figure on the left using cushioning tape.

■ LED lamp (driver's side) installation

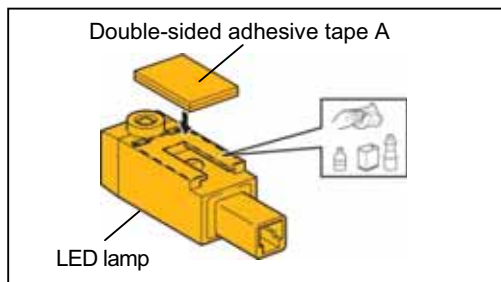

1. Affix the double-sided adhesive tapes A to the LED lamp as shown in the figure.

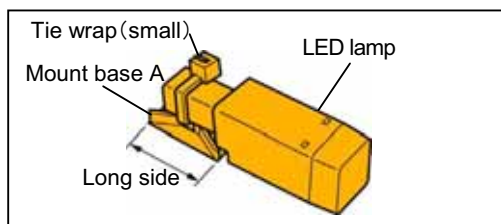

2. Pass a tie wrap (small) through mount base A and secure the LED lamp.

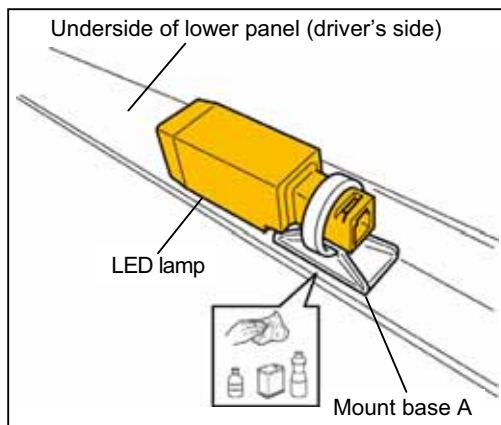

3. Peel off the paper backings of double-sided adhesive tape A and the mount base A, align the LED lamp with the hole drilled (9 mm diam.) in the lower panel (driver's side) and adhere the LED lamp.

CAUTION

- Make sure that the LED lamp does not ride on the mount base because the necessary adhesive strength cannot be obtained.

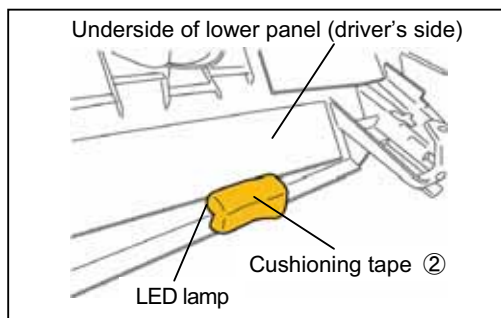

4. To prevent noise, apply the cushioning tape (2) to the top of the LED lamp.

■ LED lamp (passenger's side) installation

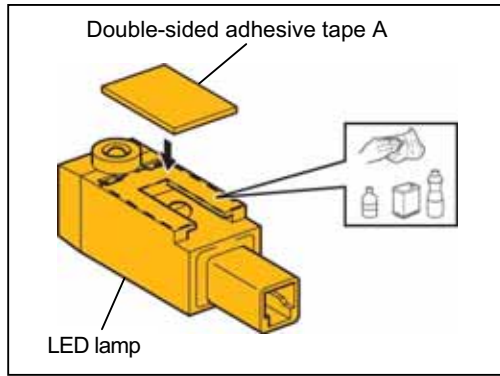

1. Affix the double-sided adhesive tape A to the LED lamp as shown in the figure.

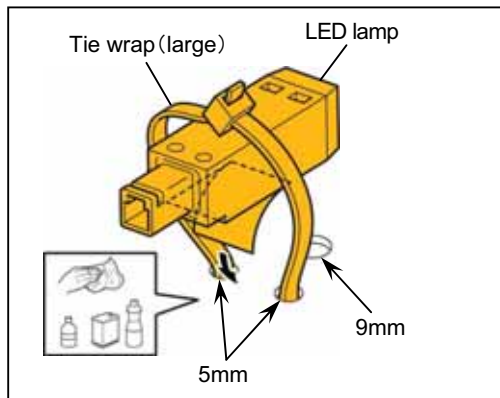

2. Peel off the backing from the double-sided adhesive tape A, insert the light-emitting part of the LED (projection) through the 9.0 mm hole of the dashboard under cover and affix. At this time, be careful that the 5.0 mm holes are not covered by the LED lamp.
3. Route a tie wrap (large) through the 5.0 mm holes and around the affixed part of the LED lamp and secure.

7. INSTALLATION OF THE MAIN HARNESS

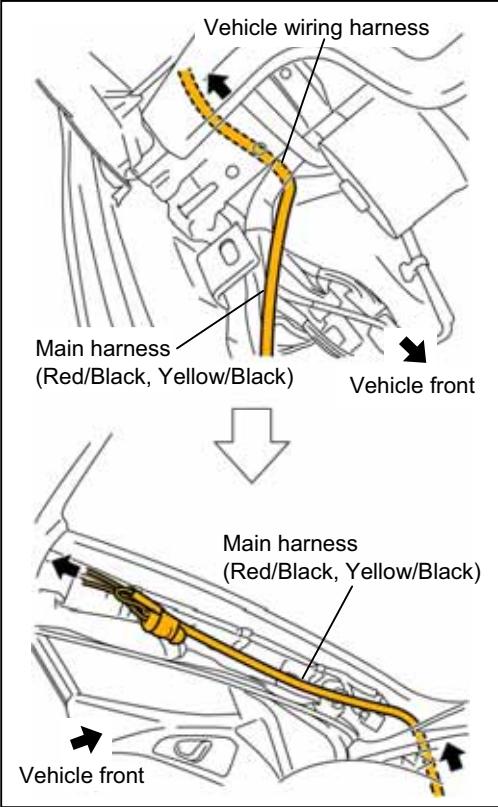

1. Pull the main harness (Red/Black, Yellow/Black) along the vehicle wiring harness behind the glove compartment and behind the A-pillar trim (driver's side).

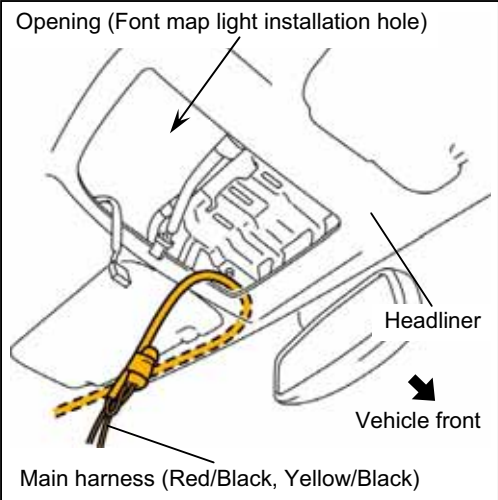

2. Pull the main harness (Red/Black, Yellow/Black) in the headliner to the opening (overhead console installation hole).

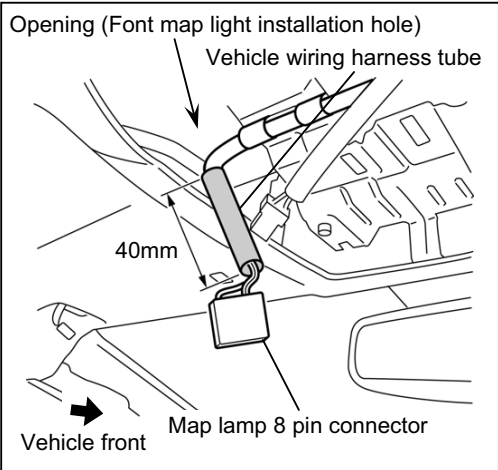

3. Cut the vehicle wiring harness tube.

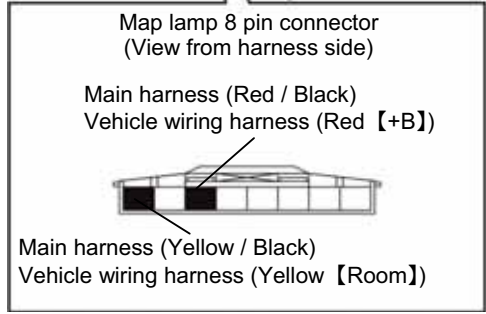
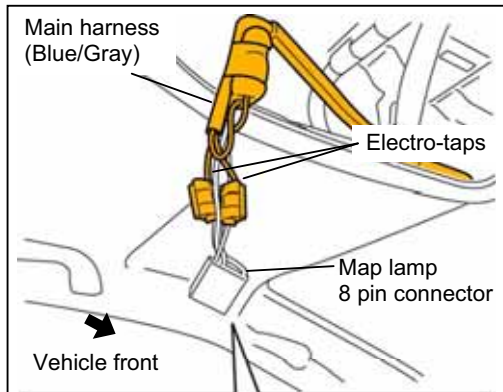

4. Connect each of the 2 wires of the main harness using an electro-tap according to the table below.

Main harness wire color	Vehicle wiring harness wire color	Circuit
Red / Black	Red	+B
Yellow / Black	Yellow	Room

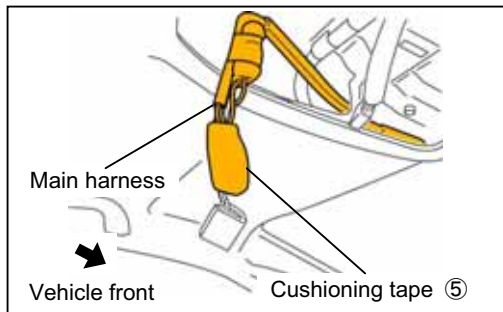

5. Wrap cushioning tape ⑤ around the electro-tap together with the main harness.

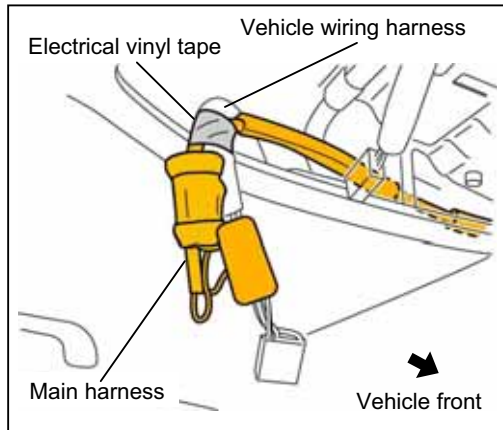

6. Secure the main harness to the vehicle wiring harness at location using electrical vinyl tape.

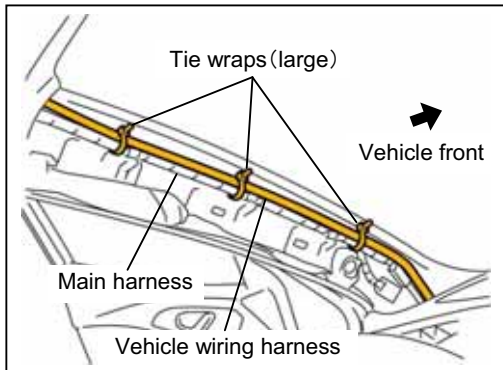

7. Secure the main harness to the vehicle wiring harness at 3 locations using tie wraps (large).

⚠ CAUTION

- If the vehicle doesn't have a vehicle harness, use the ⑥⑦ ⑧ cushion tape to fix the main harness to the vehicle body.

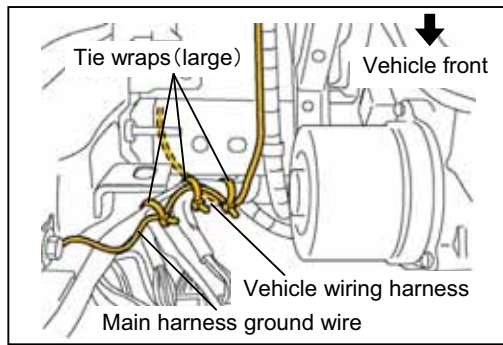

8. Secure the main harness ground wire to the vehicle wiring harness at 3 locations using tie wraps (large).

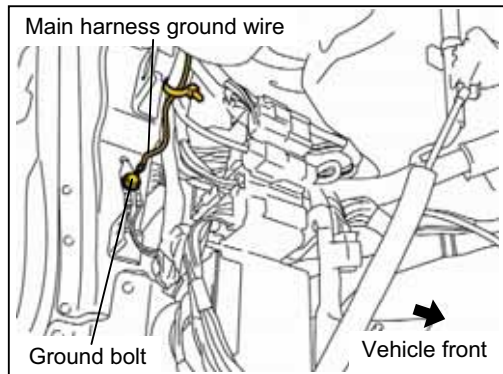

9. Tighten the main harness ground wire together with the ground bolt on the vehicle side.

Ground Bolt tightening torque : 8.8–12.7 N·m

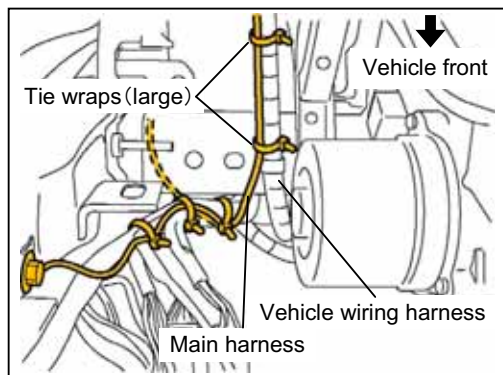

10. Secure the main harness to the vehicle wiring harness at 2 locations using tie wraps (large).

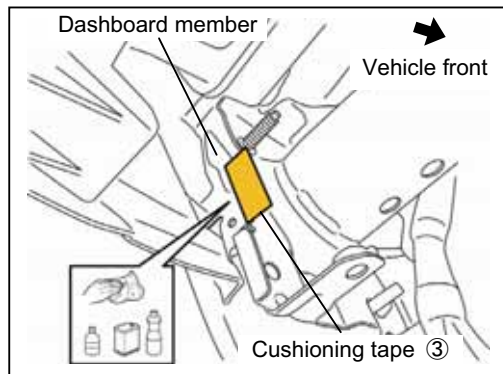

11. Apply cushioning tape ③ to the dashboard member.

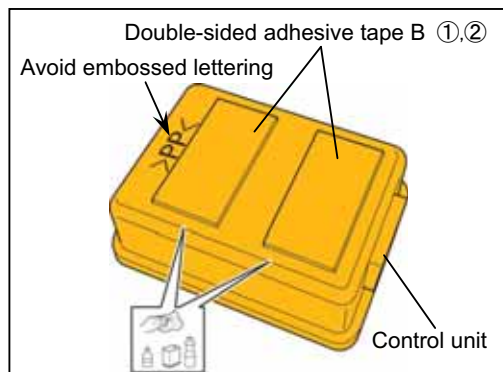

12. Affix the double-sided adhesive tape B ①,② to the Control unit as shown in the figure.

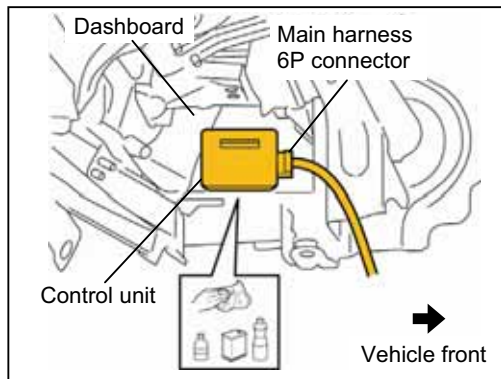

13. Connect the main harness 6P connector to the control unit.
14. Peel off the paper backing of the double-sided adhesive tape and adhere the main harness 6P connector, connected to the control unit, to the dashboard with it pointed towards the vehicle front.

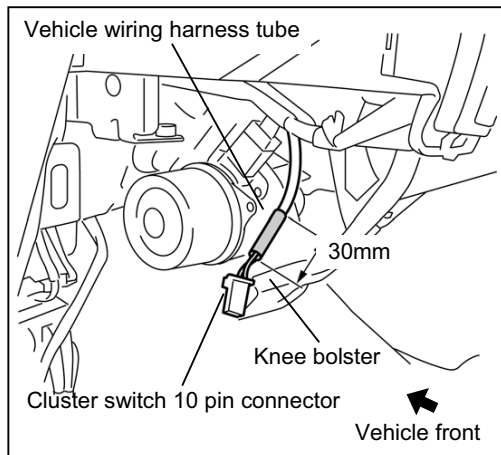

15. Cut the vehicle wiring harness tube.

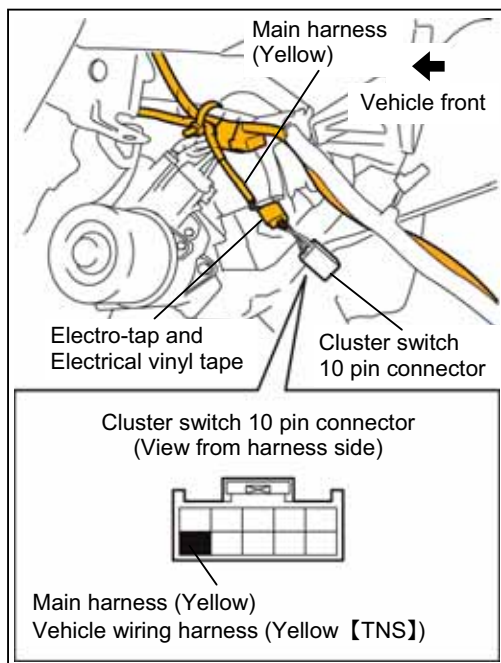

16. Connect each of the wire of the main harness using an electro-tap according to the table below.

Main harness wire color	Vehicle wiring harness wire color	Circuit
Yellow	Yellow	TNS

17. Wrap the electro taps and vehicle wiring harness together using electrical vinyl tape.

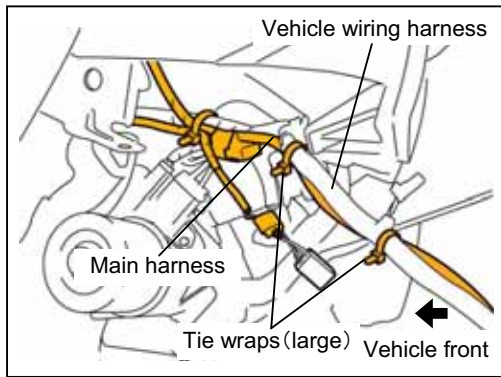

18. Secure the main harness to the vehicle wiring harness at 2 locations using tie wraps (large).

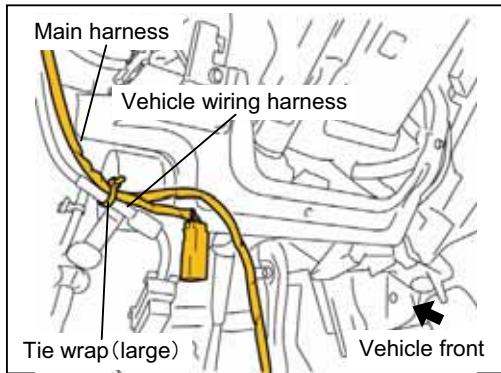

19. Secure the main harness to the vehicle wiring harness at 1 location using tie wrap (large).

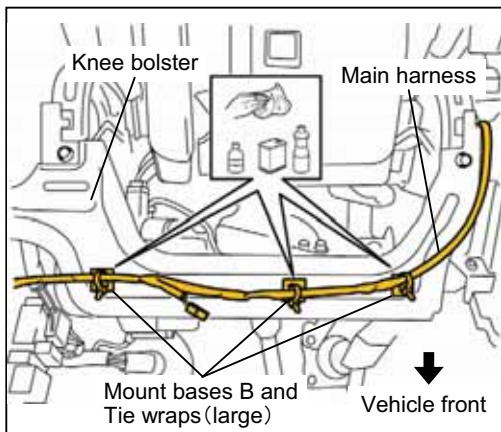

20. Affix the mount bases B to the knee bolster. (3 locations)

21. Secure the main harness to the mount bases using 3 tie wraps (large).

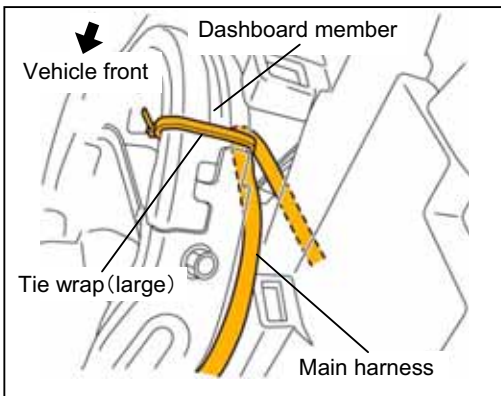

22. Secure the main harness to the dashboard member at 1 location using tie wrap (large).

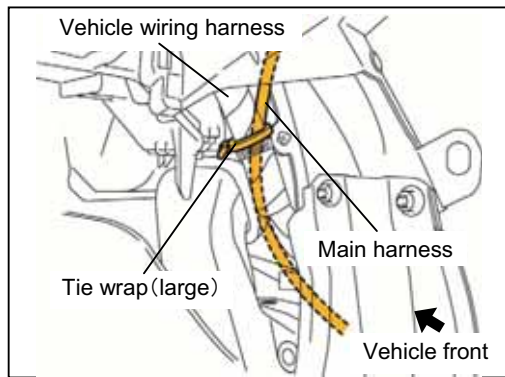

23. Secure the main harness to the vehicle wiring harness at 1 location using tie wrap (large).

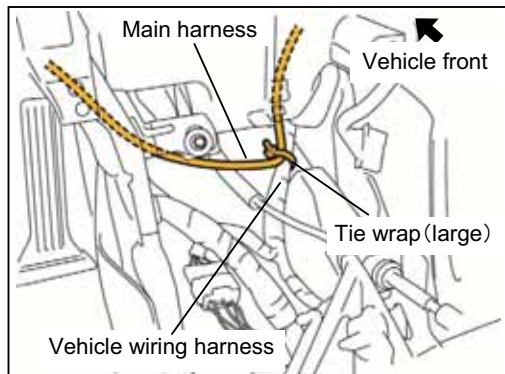

24. Secure the main harness to the vehicle wiring harness at 1 location using tie wrap (large).

⚠ CAUTION

- Do not secure the harness to the wire.

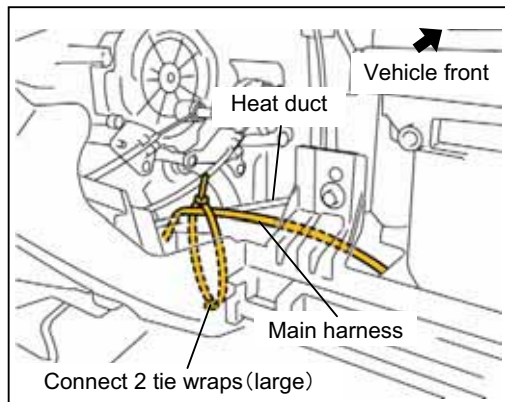

25. Pull the main harness above the heat duct.

26. Connect 2 tie wraps (large) and secure the main harness.

⚠ CAUTION

- Never secure the main harness to the vehicle wiring harness here.

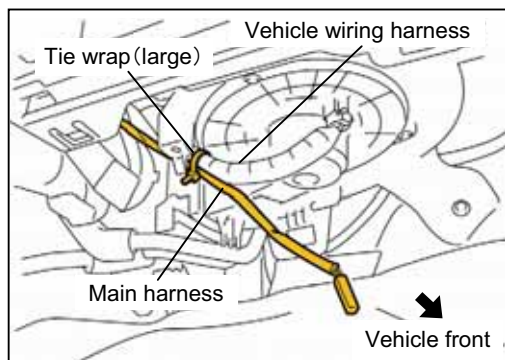

27. Secure the main harness to the vehicle wiring harness at 1 location using tie wrap (large).

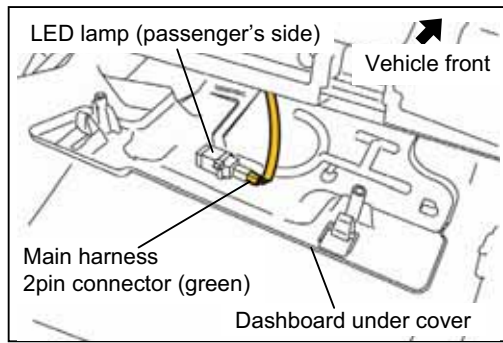

28. Connect the 2pin connector (green) of the main harness to the LED lamp (passenger's side) and temporarily re-install the dashboard under cover.

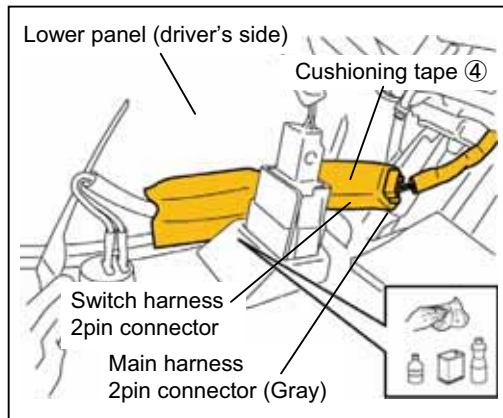

29. Connect the main harness 2P connector (Gray) to the switch harness and wrap with cushioning tape (4).

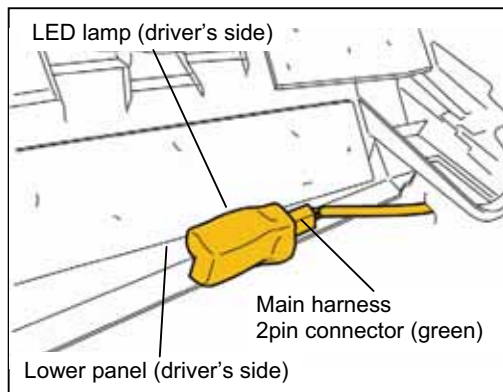

30. Connect the 2pin connector (green) of the main harness to the LED lamp (driver's side) and temporarily re-install the lower panel (driver's side).

8. OPERATION CHECK

1. Reinstall parts in the reverse order of the installation procedure in [5.VEHICLE PARTS REMOVAL] .
2. Refer to "Required servicing after disconnecting/connecting negative battery cable" in the vehicle workshop manual or the owner's manual to restore the vehicle functions.
3. Perform reinstallation and inspection of the vehicle parts.

Date , ,					
VIN.					
Approved		Checked		Person in charge	

INSTALLATION INSPECTION SHEET	MAZDA3	Interior Lighting Kit
		BHP1 V7 050

Perform the following inspections

⚠ WARNING

- Before starting the engine, make sure there are no persons in front of or behind the vehicle, or around the engine compartment. Otherwise a serious accident could result by the vehicle suddenly moving.
- Do not start the engine in a place such as a garage or other location with poor air ventilation. Otherwise, poisoning or asphyxiation could result from accumulation of exhaust gas.
- Always set the wheel blocks on level ground before performing the verification.

1. Inspection items after installation

- Verify the fitting between the vehicle part and the installed part, and inspect for damage or dirt.
- When connecting connectors, verify the connection again to prevent poor connection or mis-connection. (Insert two times.)

2. Vehicle parts reinstallation

Inspection Parts	Inspection Items	Inspection	Check
Negative battery cable	Torque check	Are the battery cables securely tightened to the terminals?	<input type="checkbox"/>
Function restore procedure after removal/installation of battery	Operation check	Have the vehicle's functions been restored by referring to "Required servicing after disconnecting/connecting negative battery cable", in the vehicle workshop manual or the owner's manual?	<input type="checkbox"/>
Decoration panel	Turns on/off	Verify hazard warning light illumination.	<input type="checkbox"/>
Rear consol	Operation check	Does the accessory socket operate?	<input type="checkbox"/>
Lower panel (driver's side)	Operation check	<ul style="list-style-type: none"> • Verify that bonnet release lever and fuel lid opener lever open. • Verify that trunk lid opener switch works correctly. 	<input type="checkbox"/>
Sunvisor	Turns on/off	Open the vanity mirror and verify that it illuminates.	<input type="checkbox"/>
Over head console	Turns on/off	Turn map lamp switch on/off and verify that map lamp turns on/off.	<input type="checkbox"/>
	Operation check	Verify that moon roof operates. (Only vehicles with moon roof)	<input type="checkbox"/>

— Continued backside —

※ The term of validity for this sheet: 3 Years

3. Installation of accessory, operation check

Perform the following operation verification with the map lamp switch in the center, "Door" position.

Inspection Parts	Inspection Items	Inspection	Check
Interior lighting function (Door-linked)	Operation check	Open and close a door and verify that the interior light turns on/off in conjunction with the door open/close, and that the LED lamp turns on/off.	
Headlight function (Headlight switch-linked)	Operation check	With the door closed (map light off), verify that the LED lamp illuminates in a dimmed state when the vehicle headlight switch is turned to "D" or "D "	
Foot illumination switch	Operation check	With the LED lamp turned on in conjunction with the light switch, switch on/off and verify that LED lamp turns on/off.	
Ground	Torque check	Is the ground tightened to the specified torque?	

MAZDA3 Interior Lighting Kit Template

BHP1 V7 050

001

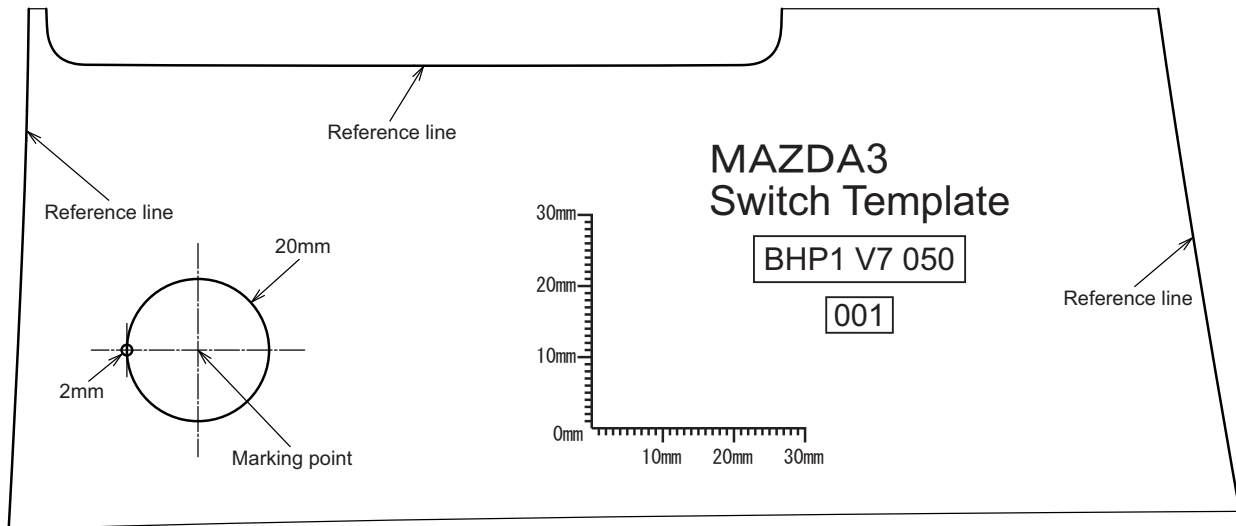

MAZDA3 LED Lamp Template

BHP1 V7 050

001

